

ELECTRICAL ENGINEERING
Paper – II

Time Allowed : Three Hours

Maximum Marks : 300

Question Paper Specific Instructions

Please read each of the following instructions carefully before attempting questions :

*There are **EIGHT** questions divided in **TWO** sections.*

*Candidate has to attempt **FIVE** questions in all.*

*Questions No. **1** and **5** are **compulsory** and out of the remaining, **THREE** are to be attempted choosing at least **ONE** question from each Section.*

The number of marks carried by a question / part is indicated against it.

Wherever any assumptions are made for answering a question, they must be clearly indicated.

Diagrams / Figures, wherever required, shall be drawn in the space provided for answering the question itself.

Unless otherwise mentioned, symbols and notations have their usual standard meanings.

Attempts of questions shall be counted in sequential order. Unless struck off, attempt of a question shall be counted even if attempted partly.

Any page or portion of the page left blank in the Question-cum-Answer Booklet must be clearly struck off.

*Answers must be written in **ENGLISH** only.*

SECTION A

- Q1. (a)** Determine the values of slope K_1 , K_2 , K_3 and the voltages L_+ and L_- for the amplifier and its transfer characteristics shown in the figure given below : 12

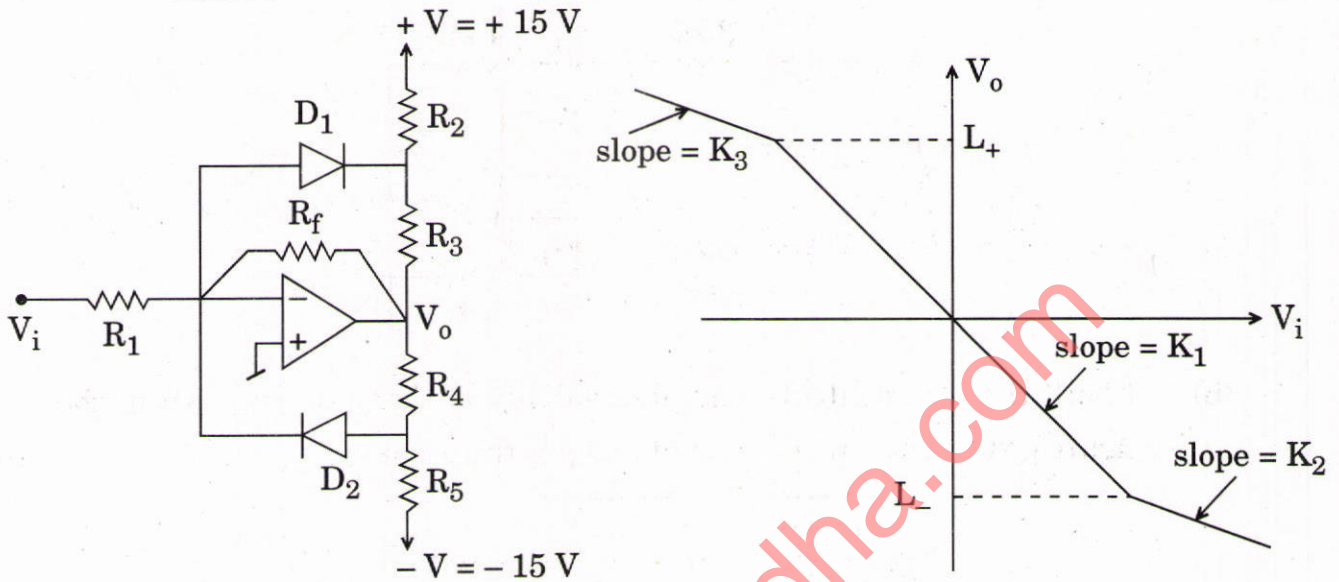

($R_1 = 30 \text{ k}\Omega$, $R_2 = R_5 = 9 \text{ k}\Omega$, $R_3 = R_4 = 3 \text{ k}\Omega$, $R_f = 60 \text{ k}\Omega$).

The diodes may be assumed to be ideal.

- (b) Determine the total energy and average power of the following signal : 12

$$x(t) = \begin{cases} 2 & -3 \leq t \leq 3 \\ 3 - t & 3 \leq t \leq 5 \\ 0 & \text{otherwise} \end{cases}$$

- (c) Show the permissible area for the poles of a second order system which must simultaneously meet the following criteria : 12

- (i) Maximum percent overshoot $\leq 5\%$
- (ii) Settling time for 2% criterion $\leq 500 \text{ ms}$

- (d) A 1000 VA, 440/220 V single-phase two-winding transformer is connected as autotransformer to supply a load at 440 V from a supply voltage of 660 V ac mains. Draw the schematic diagram of the autotransformer with proper labelling. If the full load unity power factor (pf) efficiency of the two-winding transformer is 96.2%, what will be the full-load efficiency of the autotransformer at 0.85 pf lagging ? Also find the maximum primary and secondary currents of the autotransformer. 12

- (e) The reverse recovery time of a diode is $t_{rr} = 6 \mu\text{s}$, and the rate of fall of the diode current $di/dt = 10 \text{ A}/\mu\text{s}$. If the softness factor $SF = 0.5$,

- (i) Find the storage charge Q_{RR} ,
- (ii) Find the peak reverse current I_{RR} , and
- (iii) Draw the labelled reverse recovery characteristics.

12

- Q2.** (a) Determine the value of v_p , v_n and v_{out} in the circuit given below which uses an ideal operational amplifier. Find a resistance R that, when connected in parallel with the 1 mA source, will cause v_{out} to drop to half its value when R is not present.

20

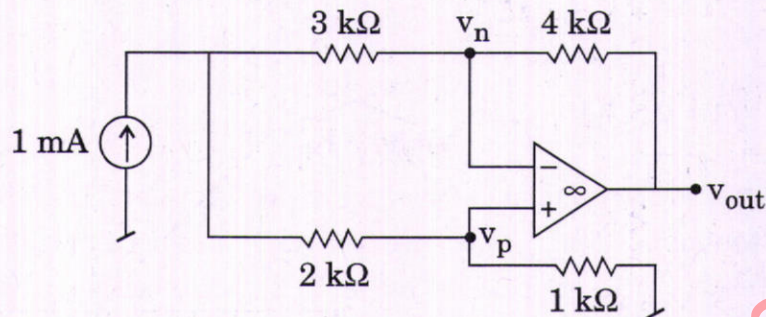

- (b) Check the controllability and observability of the system shown in the figure given below. u is the input and y is the output.

20

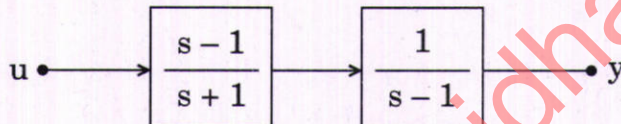

- (c) A single-phase thyristor controlled bridge rectifier is supplying a dc load of 1 kW. A 1.5 kVA isolation transformer with a source side voltage rating of 120 V at 50 Hz is used. It has total leakage reactance of 8% based on its rating. The source voltage of nominally 115 V is in the range of $\pm 10\%$. Assuming load current is nearly constant, find
- The minimum turns ratio of the transformer, if the dc load voltage is to be regulated at constant value of 100 V,
 - The reduction in average load voltage due to commutation, and
 - The value of firing angle α when the source voltage is $115 + 10\%$ V.

20

- Q3.** (a) A salient-pole synchronous motor (with negligible armature resistance and $X_d = 23.2 \Omega$ and $X_q = 14.5 \Omega/\text{phase}$) can support a maximum load of 563 kW without field excitation.

This motor is now excited with nominal field current and the motor is loaded with a load torque of 3.82 kN-m. If the motor draws armature current at 0.8 power factor (leading), determine excitation emf and corresponding power angle (δ).

20

- (b) (i) Fourier transform of a periodic signal is given as

$$X(j\omega) = j\delta\left(\omega - \frac{\pi}{3}\right) + 2\delta\left(\omega - \frac{\pi}{7}\right).$$

Determine the fundamental angular frequency and the Fourier series coefficients. Then determine the corresponding time signal.

- (ii) Determine the Laplace transform and the ROC for the signal

$$x(t) = e^{at} u(t - k). \quad 20$$

- (c) A Buck-Boost converter is operating at 20 kHz with Inductor $L = 50 \mu\text{H}$. The output capacitor C is sufficiently large and source voltage $V_d = 15 \text{ V}$. The output is to be regulated at 10 V and the converter is supplying a load of 10 W. Find

- (i) The duty ratio D , and
(ii) Maximum value of Inductor current. 20

- Q4.** (a) The open loop transfer function of a unity feedback system is given by

$$G(s)H(s) = \frac{K}{(s + 20)(s^2 - 2s + 1)}.$$

Use Nyquist stability criteria to find the range of K for closed loop stability. 20

- (b) Draw and elaborate (with appropriate mathematical justification) the graphical locus of induction motor (voltage, current and power) for a complete range of slip from approximate equivalent circuit model. Justify its circular nature for naming it as circle diagram of induction motor.

Also, state and explain with the help of the circle diagram, how to obtain rotor/stator copper losses, torque and slip at any arbitrary point on circle diagram. 20

- (c) Draw the wiring diagram showing currents for power and relaying circuit used for protecting a transformer of the rating 25 MVA, 220 Y/13.8 Δ kV, $X = 10\%$. The transformer has a short-term overload capacity of 30 MVA. You are required to use CTs with common turns ratios such as 50/5A, 100/5A, 150/5A, ..., 1000/5A, 1200/5A. If needed, auxiliary CT of adequate turns ratio may be used. 20

SECTION B

Q5. (a) The transfer function of a linear system is given by $G(s) = \frac{10}{(s+1)(s+2)}$. The sinusoidal steady state response of the system to an input is given by $1 + \sin(t - 60^\circ) + 5 \sin(2t - 45^\circ)$. Determine the input. 12

(b) Draw phasor diagram of an over-excited salient-pole synchronous motor having armature resistance R_a , d- and q-axis reactances X_d and X_q respectively. Also prove, for lagging power factor

$$\tan(\phi - \delta) = \frac{V_t \sin \phi - I_a X_q}{V_t \cos \phi - I_a R_a}$$

where V_t is the terminal voltage applied to motor, ϕ being the power factor angle, δ is power angle and I_a is armature current. 12

(c) A flyback converter has the following circuit parameters :

$$V_s = 24 \text{ V}$$

$$N_1/N_2 = 3$$

$$L_m = 500 \mu\text{H}$$

$$R = 5 \Omega$$

$$C = 200 \mu\text{F}$$

$$f = 25 \text{ kHz}$$

$$V_o = 10 \text{ V}$$

Find

- (i) The average magnetizing current, and
- (ii) The critical value of magnetizing inductor. 12

(d) A 220 kV three-phase transmission line is 90 km long. The resistance is $0.1 \Omega/\text{km}$ and the inductance is $1.0 \text{ mH}/\text{km}$. Use the short transmission line model to find

- (i) Voltage at the sending end, and
- (ii) Voltage regulation at the sending end. 12

(e) A 12-bit dual-slope ADC utilizes a 1 MHz clock and has $V_{\text{ref}} = 10 \text{ V}$. Its analog input voltage is in the range of 0 to -10 V . Find out the time required to convert an input signal equal to the full-scale value. Also find the integrator time constant if the peak voltage reached at the output of the integrator is 10 V . 12

- Q6.** (a) A 50 Hz, 4-pole turbogenerator rated 500 MVA, 22 kV has an inertia constant of 7.5 MJ/MVA. Find
- Rotor acceleration, if the input to the generator is suddenly raised to 400 MW for an electrical load of 350 MW,
 - The speed of rotor in rpm, if the rotor acceleration calculated in part (i) is constant for a period of 10 cycles, and
 - The change in torque angle δ in elect. degrees. 20
- (b) The full bridge inverter is used to produce a 50 Hz voltage across a series RL load using Bi-polar PWM. The dc input to the bridge is 200 V, the frequency modulation m_f is 21 and amplitude modulation m_a is 0.8. The load has resistance of $R = 10 \Omega$ and inductance $L = 20$ mH. Find
- The amplitude of fundamental voltage and current, and
 - Total harmonic distortion in load current. 20

Assume harmonics ($> 25^{\text{th}}$ order) are insignificant and normalized voltage is

$m_a = 1$		0.9	0.8	0.7	0.6	0.5
$n = 1$	1.0	0.9	0.8	0.7	0.6	0.5
$n = m_f$	0.6	0.71	0.82	0.92	1.01	1.15
$n = m_f \pm 2$	0.32	0.27	0.22	0.17	0.13	0.09

- (c) Design a circuit that takes as input two 2-bit numbers, N_1 and N_2 for comparison and generates three outputs :
- $N_1 = N_2$, $N_1 < N_2$ and $N_1 > N_2$. These three binary outputs are represented by F_{eq} , F_{lt} and F_{gt} respectively. Realize the outputs in Sum of Products (SoP) form. 20

- Q7.** (a) For a causal system specified by the transfer function

$$H(z) = \frac{z}{z - 0.5}$$

determine the zero state response to the input

$$r(k) = (0.8)^k u(k) + (2)^{k+1} u[-(k + 1)]. \quad 20$$

- (b) An unbalanced 2- ϕ , 1000 V, 50 Hz induction motor has unequal winding impedances $Z_a = 3 + j2.7$ and $Z_b = 7 + j3 \Omega$. This motor is supplied by Scott-connected transformer combination from a 3-phase 11 kV system. Calculate phase currents I_a and I_b of the motor and line currents on 3-phase supply side. 20

(c) A 25 MVA, 13.8 kV generator with $X_d'' = 15\%$ is connected through a 25 MVA, 13.8/6.9 kV transformer with leakage reactance of 10% to a bus which supplies four identical motors as shown in the figure. The sub-transient reactance X_d'' of each motor is 20% on base of 5 MVA, 6.9 kV. Find

- (i) The sub-transient current in the fault, and
- (ii) The sub-transient current in breaker A.

20

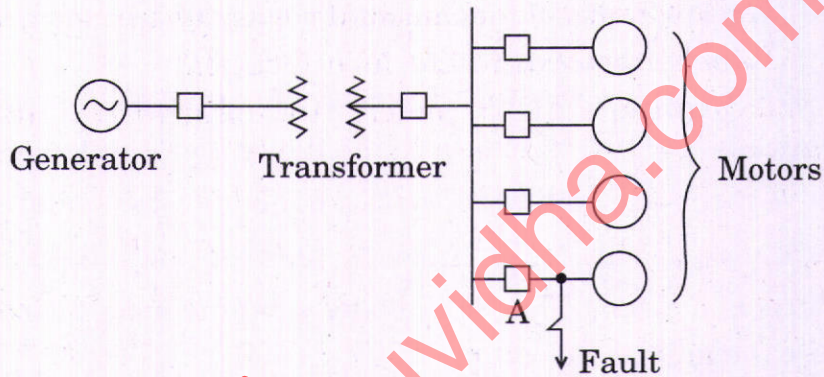

Q8. (a) Find the transfer function $\frac{Y(s)}{U(s)}$ using Mason's Gain formula. Also find $\frac{X_5(s)}{U(s)}$.

20

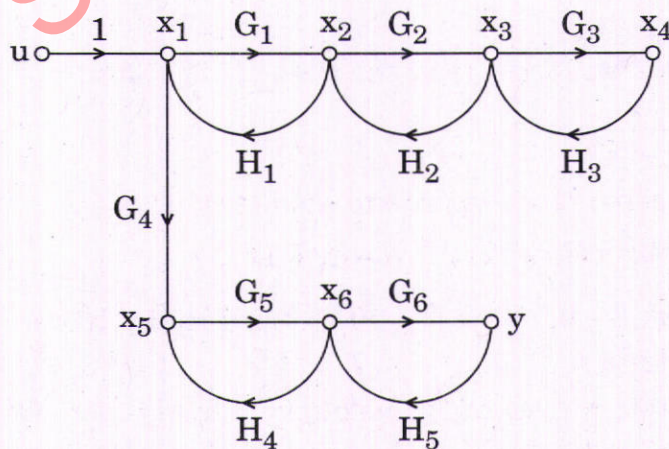

- (b) A 440 V, 50 Hz, 6-pole, Y-connected induction motor has following parameters per phase referred to the stator :

$$R_s = R_r' = 0.3 \Omega, X_s = X_r' = 1.0 \Omega, \text{ and } X_m = 40 \Omega.$$

The nominal full load slip is 0.05.

The motor is to be braked by plugging from its initial full load condition. Determine initial braking torque without braking resistor (R_B).

Also find the value of R_B so that braking current is limited to 1.5 times the full load current. What will be the corresponding braking torque as a ratio of full load torque ?

20

Note : Assume braking resistor R_B is connected to rotor circuit.

- (c) A generator is connected by a double line to an infinite bus, the voltage of which is $V = 1$ pu as shown in the figure. Per unit values of reactances and voltages are indicated in the figure. A three-phase short circuit occurs at the point P. The circuit breakers A and B open simultaneously and remain open. The mechanical power supplied to the generator before the fault is $P_m = 1$ pu.

- Determine the electrical powers P_{e1} , P_{e2} and P_{e3} before, during and post the fault.
- Draw on the same graph, power angle curves for P_{e1} , P_{e2} and P_{e3} .
- Calculate the angles δ_0 , δ_1 and δ_{\max} where δ_0 is the initial power angle, δ_1 is the post fault power angle and δ_{\max} is the maximum power angle.

20

